



GMNIAIRE 2200C HEPA Air Filtration Machine



Operation and Maintenance Manual

WARNING

Do not use with combustible or explosive material. Do not expose to water or rain. Connect only to grounded outlet with GFCI device. Disconnect power for cleaning and servicing. This equipment to be operated only by trained personnel.

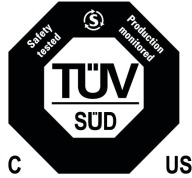

CONFORMS TO UL STD 507
CERTIFIED TO CAN/CSA STD
C22.2 NO. 113-M1984

Safety Warning Instructions:

READ AND SAVE THESE INSTRUCTIONS

This equipment to be operated only by trained personnel.

Do not use with combustible or explosive material.

Do not expose to water or rain.

Connect only to grounded outlet with GFCI device.

Disconnect power for cleaning and servicing.

Do not operate if cord or plug is damaged. Contact a authorized service facility for examination and/or repair.

Do not run cord under carpeting. Do not cover cord with throw rugs, runners, or similar coverings. Arrange cord away from traffic areas and where it is not a tripping hazard.

Avertissement de sécurité Instructions:

LIRE ET CONSERVER CES INSTRUCTIONS

Cet équipement doit être utilisé que par un personnel formé.

Ne pas utiliser avec des matières combustibles ou explosives.

Ne pas exposer à l'eau ou à la pluie.

Connectez uniquement à une prise mise à la terre avec un dispositif GFCI.

Coupez l'alimentation électrique pour le nettoyage et l'entretien.

Ne pas utiliser si le cordon ou la fiche est endommagé. Contactez un centre de service autorisé pour examen et / ou réparation.

Ne pas passer le cordon sous un tapis. Ne pas couvrir le cordon avec des carpettes, les coureurs, ou revêtements similaires. Éloigner le cordon des endroits passants et où il n'est pas un risque de déclenchement.

OmniAire 2200C is a construction grade negative air machine with two speeds, powerful blower and full size, 12" deep HEPA filter. This is a well-constructed and reliable air scrubber with many accessories to remove airborne particulates and biocontaminants. The 2200C is used to create positive or negative pressure at asbestos, lead and mold abatement projects. For collection of construction dust from cutting or grinding of concrete, wood or plaster, the HEPA filter can be replaced with an economical multi-pocket bag filter. For VOCs and odor control, VaporTrap or OdorGuard activated carbon filters can be quickly installed.

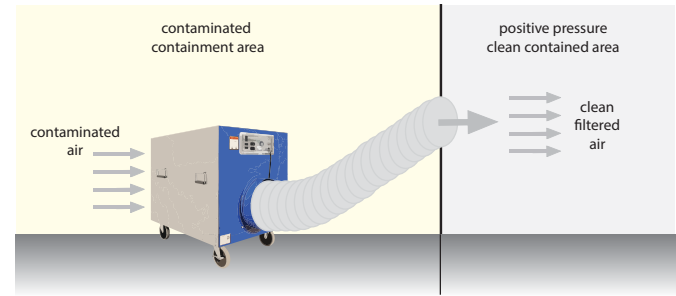
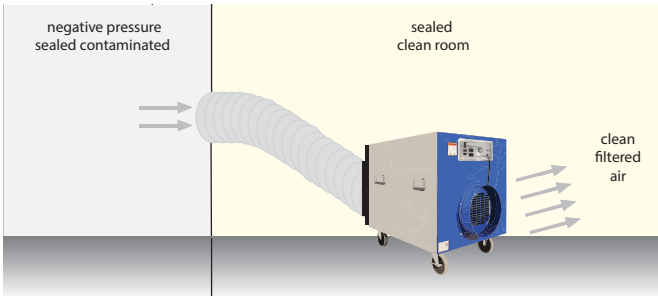

To create **NEGATIVE PRESSURE** inside the containment, more air has to be exhausted out than leaks into the containment. Place the machine inside the containment and hook a flexible duct to the outlet ring of the machine exhausting to outside the containment. (See Above) All of the air being exhausted has been treated by the HEPA filter so no contaminants are being exhausted from the containment.

To create **POSITIVE PRESSURE** inside the containment, more air has to be pumped in than leaks out of the containment. Place the machine outside the containment and hook a flexible duct to the outlet ring of the machine ducting the exhaust into the containment. (See Above)

OmniAire 2200C Specifications

Airflow: 1000/2000 CFM

Power Requirements: 115 VAC/60 Hz/11.1 Amp

Motor: 1.25 HP with thermal overload

Filtration: HEPA 99.97%, 0.3 μ filter; MERV 9 primary/secondary filter

Optional Filtration: OdorGuard 600 activated carbon filter; VaporTrap V-Bank 36 lbs; HEPA 99.99%, 0.3 μ filter, MERV 15 bag filter

Recessed Controls: HIGH/OFF/LOW speed switch; amber change filter indicator light; red power indicator light

Housing: galvanized metal, silicone sealed before riveting; (4) rubber grip handles; (2) 5" hospital grade locking casters, (2) 5' rigid hospital grade casters

Exhaust Collar: 12" diameter

Size/Weight with Filters: 28"W x 32"H x 35"L, 147 lbs.

Receiving Instructions

Visually inspect the unit for damage. Remove the primary/secondary filter and ensure that the HEPA filter has not been dislodged during shipping. The HEPA filter should be sitting on the filter guides and the filter tabs that hold the HEPA filter in place should be tight.

If the filter is not seated correctly then remove the filter tabs, reposition the filter, and reinstall the filter tabs before operation to ensure that there is no bypass around the filter. If the filter tabs are loose verify that the filter is in the correct position and re-tighten the filter tab nuts.

Operation

For Asbestos and mold abatement, the machine must be operated with a HEPA filter in place. Also, it is recommended to use the primary/secondary filter and replace it frequently to extend the life of the HEPA.

Start the machine

Place the switch in the HIGH or LOW position to turn the machine on. When filters are clean, the REPLACE FILTER indicator light will be off. As the filters fill with dust the efficiency of the filters is maintained, but the air flow will decrease and the differential pressure across the filter increases. Change the primary/secondary filter frequently to protect the HEPA and to get more air flow. When amber indicator light comes on, the REPLACE FILTER indicating light will turn on and the HEPA filter will have to be replaced to increase the air flow. Additional accessories such as an optional intake manifold can be used on the suction side of the unit providing 12" connection for the flex duct. The discharge side of the unit has a 12" diameter ring for a flex duct.

Maintenance

The blower and motor do not require any maintenance when the machine is operated with the HEPA filter in place.

Pre-filter Replacement

The primary/secondary filter should be changed when the orange side shows it is loaded with dust. Changing the filter can be done while the machine is running. Ensure that the orange side of the prefilter is facing the HEPA filter.

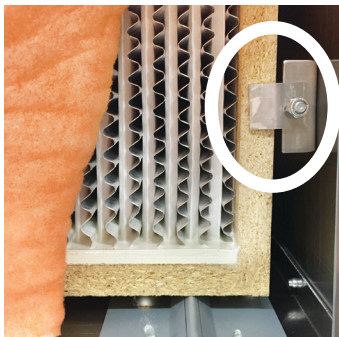

filter tab

HEPA Filter Replacement

During your projects, your HEPA filter purifies the air and gradually becomes loaded with sub-micron particulates. Even when the HEPA filter is fully loaded, the filter is still removing particulates from the air at the rated efficiency yet at a reduced airflow. This will affect the ability of the machine to provide positive or negative pressure within the containment.

To replace the HEPA filter unplug the machine and remove the screen/manifold to remove the prefilter. You will see 4 filter tabs holding the HEPA filter in place (see photo).

These tabs are secured with 1/4-20 Nylock nuts, which require a 7/16" wrench or socket.

Remove all 4 filter tab retaining nuts and remove the filter tabs and set aside. Slide the HEPA filter out along the filter guides and remove it from the machine. ALWAYS TREAT THE USED HEPA FILTER AS HAZMAT AND PROCESS IT ACCORDING TO YOUR ESTABLISHED HAZMAT PROCEDURES.

To replace the HEPA filter ensure that the gasket on the HEPA filter faces inwards toward the flange, slide the filter in place along the filter guides and re-install the filter tabs and filter tab securing nuts. The nuts should initially be tightened to where the stud is flush with the end of the nut. This will compress the gasket on the filter approximately 1/2 of the thickness. This allows for the filter to be resealed and tightened at a later time if necessary.

Bag Filter Replacement

For the projects that do not require a HEPA filter, the economical bag filter can be used to control the dust at construction sites. The bag filter housing can be installed in place of the HEPA filter. The Bag filter with a MERV 15 rating and multi pocket configuration has a large dust holding capacity and requires replacement when the airflow of the machine drops below your required minimum flow. Typically bag filters do not require the use of prefilters.

The bag filter housing can be installed in the place of the HEPA filter using the filter tabs and Nylock nuts. The bag filter is secured inside the housing with 4 P-clips. To remove the filter turn the P-clips 90 degrees and pull it out. Then install the new bag filter and secure it using the P-clips.

Vapor Trap Carbon Filter

Activated carbon filters are designed to remove odors and gaseous pollutants from air. These filters are an effective and quick solution to your VOCs and odor problems. The selection of the carbon filter depends on the type and amount of the gaseous pollutants. You will need to determine the requirements of your application. The Vapor Trap is a disposable V-Bank, 24"x24"x12" filter and contains 36lb of activated granular carbon. It can be installed in place of a HEPA filter. We recommend using our primary/secondary filter in front of the Vapor Trap to extend its odor absorption capacity.

Troubleshooting

Your Omnitec Design machine is designed and engineered to provide years of trouble free service. Occasionally problems occur. Here are some helpful tips and solutions.

The machine does not start

1. Check that the unit is plugged in and there is 115VAC available. Select either LOW or HIGH speed to turn the machine on. If the red indicator light comes on, power is coming to the unit from the outlet.
2. Call Omnitec technical support to troubleshoot further.

The machine just hums when turned on

1. Unplug the unit.
2. Remove the HEPA filter and push the blower wheel by hand. If it does not move freely or if you hear a grinding/scrapping noise as you spin it, then the blower wheel is touching the side of the blower housing. This may be due to an impact of some kind and the motor mounts have been bent. Remove the motor/blower assembly and replace the bent motor mounts.
3. If the blower spins freely, check the capacitor. With the HEPA filter still removed from the machine, insure that the wiring connected to the capacitor is plugged in and not broken. Re-plug the unit into the power outlet keeping the switch in the OFF position. Then push the blower wheel and as it is spinning turn the speed selector switch to LOW. If the machine keeps running, the capacitor needs to be replaced.

The machine will run for a few minutes then turn off

1. The machine must have a HEPA filter installed to operate properly. If you are trying to run it without a filter in place, the motor will overheat within a few minutes and the thermal overload will engage and shut it down. Let the motor cool off for 30 minutes, install the filter and try running the machine again.
2. If the filter is in place and the machine still shuts off after a few minutes then the motor is faulty. Replace the motor.

The machine vibrates excessively when running

1. This is an indication that the motor bearings are worn out. If the machine continues running, at this point the vibration will cause the center hub of the blower wheel to separate from the wheel requiring replacement of both the motor and blower. Replace the motor.
2. If the machine does require electrical servicing of the motor or switches the following page contains a wiring diagram to aid in repair or troubleshooting.

Ordering Info

OmniAire 2200C
 Primary/Secondary Two-Stage Filters (box of 20)
 HEPA Filter 99.99%, 0.3 μ (metal frame)
 HEPA FILTER 99.97%, 0.3 μ (pb frame)
 Bag Filter Housing (includes 1 Bag Filter)
 Bag Filter MERV 15
 Vapor Trap V-bank Filter
 OdorGuard 600 Carbon Filter
 ABS Plastic Intake Manifold, 12" Dia.
 Quick Clamp, 12"-16" Dia.
 Flexible Duct, 12" Dia. x 25' L
 Flexible Duct, Wire & Fiber Reinforced

Part

OA2200C
 OAP2424
 OAH2424G
 OAH2424L
 HBF2200
 OBF10
 OCVT2424
 OG2424D
 OAIM2200-12
 QCW14
 OAD12
 OAD12R

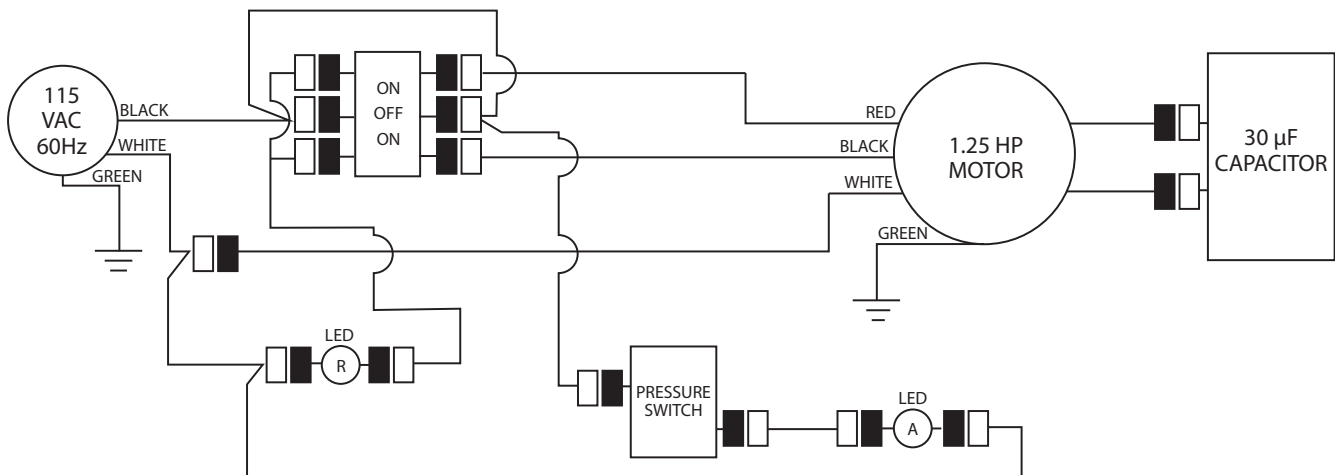

| Diagram Legend | |
|----------------|--------------------------|
| ■ | Wiring Connector |
| ⌋ | Terminated (Capped) Wire |
| Ⓡ | Red LED Light |
| ⓐ | Amber LED Light |
| ⓐ | Green LED Light |

GMNITEC
 DESIGN

4640 Campus Place, Suite 100
 T. 425.290.3922 | F. 425.290.3964

| MODEL OA2200C | | |
|-------------------------|--------------------------|-----------------|
| Wiring Diagram | | |
| DRAWN BY: A. Briceno | | REV A |
| SCALE Not to Scale | DATE November 9, 2018 | SHEET 1 of 1 |

Omnitec Design LIMITED WARRANTY

Omnitec Design warrants, for a period of twelve (12) months from the date of purchase, that all Products, component parts and accessories, excluding filters, will be free from defects in material and workmanship under normal use and service.

THE PURCHASER'S SOLE AND EXCLUSIVE REMEDY UNDER THIS WARRANTY IS LIMITED TO THE REPAIR OR REPLACEMENT OF DEFECTIVE PARTS F.O.B., Omnitec Design 4640 Campus Place Ste. 100, Mukilteo, WA 98275
Phone: 425-290-3922

In order to keep this warranty in effect for the aforementioned twelve-month period, the purchaser must (i) promptly, i.e., immediately upon discovery, inform Omnitec Design's customer service of any defects, and (ii) properly use and maintain the Product prior to the discovery of any defect.

This warranty does not cover normal wear and tear or defects caused by (i) improper or negligent handling or unauthorized modifications; (ii) defective or improper premises, chemical, or electrical influences; or (iii) weather or other forces of nature.

In order to provide the best customer service possible, Omnitec Design requests that purchaser completes the enclosed LIMITED WARRANTY REGISTRATION FORM and returns it to Omnitec Design within 30 days of purchase date.

LIMITATIONS OF WARRANTY

THIS WARRANTY IS EXPRESSLY IN LIEU OF ANY AND ALL OTHER WARRANTIES AND OBLIGATIONS OF Omnitec Design OR ITS SUPPLIERS, EXPRESS OR IMPLIED, AND Omnitec Design EXPRESSLY DISCLAIMS ANY WARRANTY OF MERCHANTABILITY OR FITNESS FOR ANY PARTICULAR PURPOSE.

LIMITATION OF REMEDY

Under no circumstances shall Omnitec Design or any supplier of Omnitec Design be liable for any loss or damage, including, but not limited to, loss or damage arising out of the failure of the Products to operate for any period of time, inconvenience, the use of rental or replacement equipment, loss of profits or other economic loss, or general, direct, special, indirect, incidental or consequential damages or property damages.

PRODUCT SUITABILITY

Many states and localities have their own varied codes and regulations governing sales, construction, installation, and/or use of Products for certain purposes. While Omnitec Design attempts to assure that its Products comply with such codes, it cannot guarantee compliance, and cannot be responsible for how the Products are installed or used. Omnitec Design recommends that, before purchasing and using a Product, purchasers review the Product application, and federal, state and local regulations, to be sure that the Products, installation, and use will comply with them.