

The **Fumex FA5 fume extractor** utilizes a high performance 3 stage hybrid air filter system to capture and treat air pollutants generated during application processes. The FA5 unit comes with either a single blower motor (**FA5-1 @ 305 cfm**) or with a double blower motor system (**FA5-2 @450 cfm**). Operator friendly digital controls and integrated electronic gas sensor continuously monitor the system performance and display operating parameters on the high-visibility LED screen. Large capacity inexpensive pre-filters extend filter change intervals and protects the large HEPA filter and gas/odor filter offering an extremely cost-effective, efficient laser engraver fume extractor system. High performance variable speed blower provides maximum application flexibility. Ideal for medium to heavy duty fume extracting applications.

Laser

Electronics

Printing

3D Printing

Mechanical Engineering

Dental

Pharmaceutical & Medical

Beauty

Other



Construction:

- Cabinet: 304 grade Brushed stainless steel to IP56 compliance
- Baffled – sound attenuated
- Sound Level: 59 dbA
- Weight: 134 lbs. / 46 kg.

Blowers:

- Performance: 305 cfm @ 39" wc FA5-1 or 450 cfm @ 39" wc FA5-2
- Variable speed blower
- Centrifugal - direct-drive, brushless motor
- Rated 20,000 hour + mtbf

Electrics/Controls:

- 90/250/1/50-60 (120v or 230v plug)
- Digital display with variable speed blower
- Pre-wired 3 wire power cable, 9 ft. with plug
- Digital Controls
- Electronic variable speed blower control
- Electronic individual filter monitoring with display
- Calibrated electronic VOC gas sensor
- Electronic digital interface relay for filter monitoring
- Amp Draw: 15.0 (120v) / 12.0 (230v)

Standard Equipment:

- UL, ULC and CE/TUV compliance available
- 8 ft. 2-ply ribbed rubber hose
- 3", 4" or 6" inlet diameter hose with clamps
- Digital graphic controls
- (4) Industrial grade wheels – two locking
- Installation guide / Operations manual

Standard Filter Set:

- 9" - Pre-Filter:
 - Large capacity box style
 - 99% efficient @ 1.0 micron
 - Deep-pleated dimpled media
- 4" - HEPA Filter:
 - 99.97% efficient @ 0.3 micron
- 4" - Gas / Odor Filter:
 - Large capacity gas/odor filter
 - Provides broad spectrum gas/odor control
 - Dustless construction suitable for all environments
 - Bonded carbon technology maximizes one pass efficiency

TECHNICAL DATA

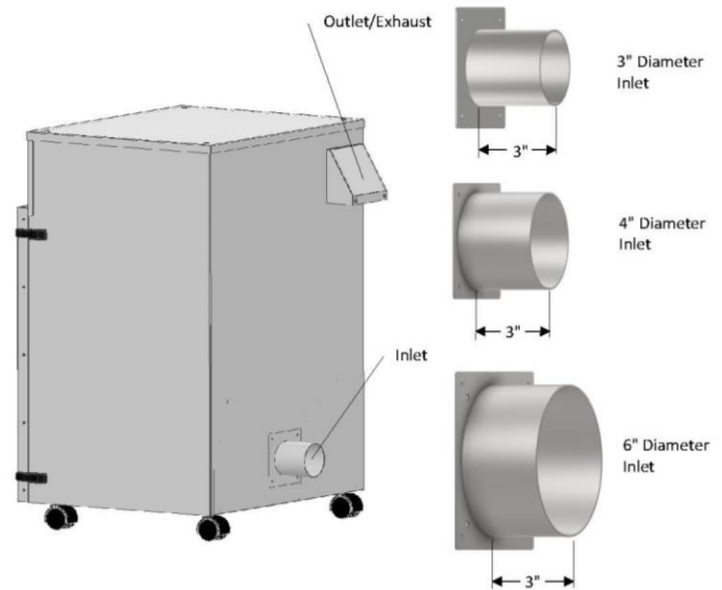
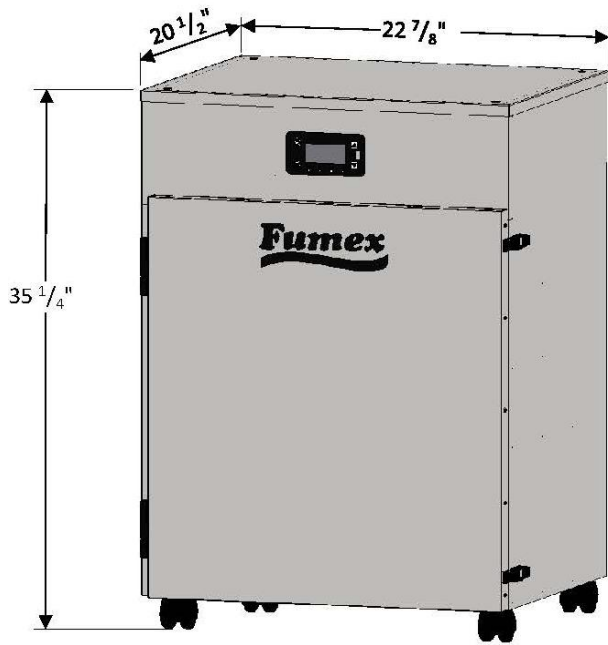

- OSHA compliance programable via USB port pressure set points, blower speeds, and VOC detection
- High visibility Graphic display indicating blower speed, filter, and unit system status
- System Data logging: monitoring blower usage, filter service intervals accessed by USB port



Large Capacity Pre-Filter (FA540B)

HEPA Filter (FA500)

Activated Carbon Gas / Odor Filter (FA501D)

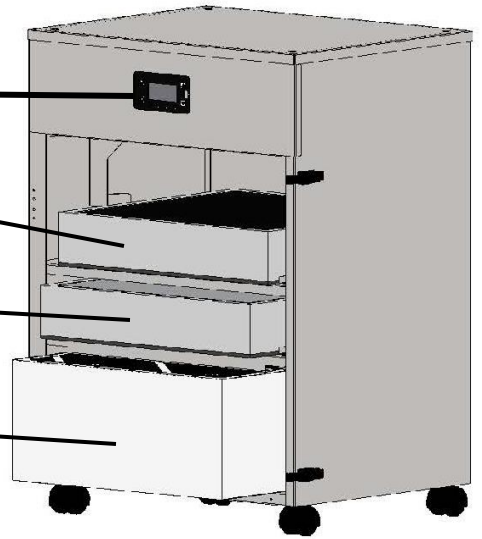

FUMEX ACCESSORIES

Source Capture Arms and Hoods



FA122



FXA-127



FXA-36-31



FXA-125



FA-127



A-28-2

Additional Application Accessories



FA150 (Spark Arrestor)



FA151 (Bench Hood)



FB1 (External High-Capacity Pre-filter)

Terms: Net 30 days with approved credit
 FOB POINT: Kennesaw (Atlanta), GA

