



A Donaldson Company

# 3D PRINTPRO 4 FUME EXTRACTOR

LAST UPDATED ON 03.01.2024

A WORLD LEADER IN FUME  
EXTRACTION TECHNOLOGY

## For large format and high-performance 3D printers

The refreshed BOFA 3D PrintPRO 4 provides a premium fume extraction system for high-performing 3D printers. With a special blend of chemical adsorbents and a high-efficiency particulate filter (HEPA), the extractor helps to filter emissions from 3D printing processes.

## Key features

- Multi-layer filtration - HEPA and gas filters
- Extended life filters for low cost of ownership
- Low noise level
- Compact construction
- Filter change indicator
- Lockable castors
- Auto-sensing voltage (100-230v) for global use
- UL/CE approvals
- Optional 24V remote stop/start interface
- Optional filter status signals to host machine
- Optional gas sensing technology
- Optional silencer box with spigot



HEPA  
filter



Advanced carbon  
filter (ACF)  
technology



Multi-voltage  
sensing unit  
(MVS)



SureCHECK  
quality  
standard

## Technical specification

1. Digital speed control
2. On/off switch
3. Filter condition display
4. Power cable inlet
5. Lid fastening latches
6. Handles
7. Hose inlet connections - 75mm
8. Exhaust outlet
9. Castors
10. Override switch
11. Signal interface
12. Optional silencer box with spigot

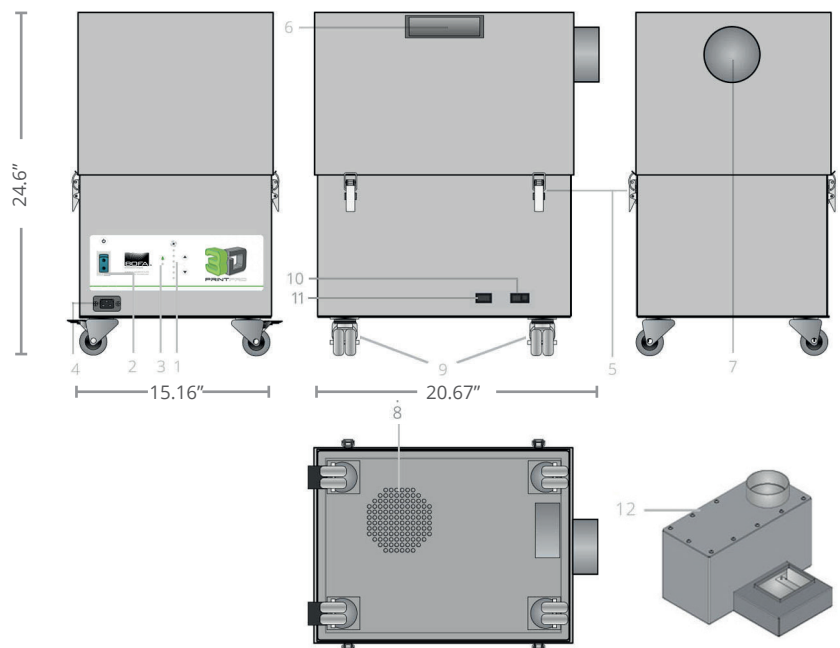

## Airflow through filters

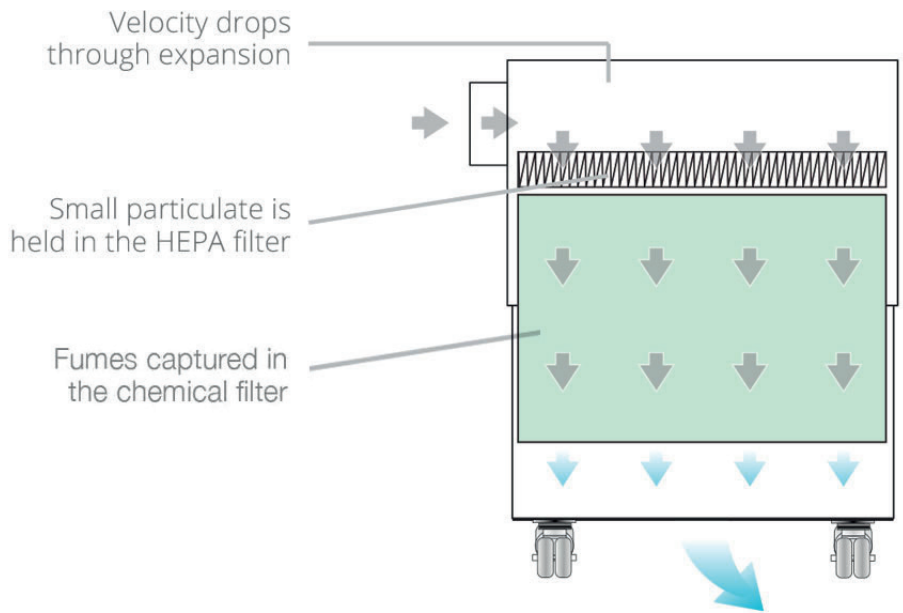
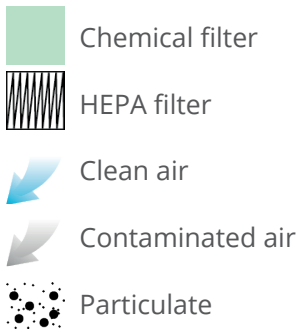

## Technical data

Dimensions (HxWxD)	24.60 x 15.16 x 20.67"
Cabinet construction	Powder-coated mild steel
Min airflow	30cfm
Max airflow	159cfm
Maximum available vacuum	100 mBar
Electrical data	115v 60/50Hz Full load current: 9.5amps
Noise level	<75dBA (at typical operating speed)
Weight	113lbs (+/- 5%)
Approvals	UKCA, CE and cUL, UL*

\* Tested to UL and cUL standards, but testing may be provided by alternate nationally recognized test laboratories. Certain product configurations may affect the UL certification. Please speak to your sales representative.

\*\* Sold Separately. For units connecting to a single 2,3,4 inch port. 1USHK-O-2, 1USHK-O-3, 1USHK-O-4

For specification not listed ask your BOFA representative for a quote.

Contact BOFA at [donaldsonbofa.com/contact/](https://donaldsonbofa.com/contact/)

Datasheet correct at time of publishing.

Where applicable, the carbon used in BOFA units is capable of removing a wide range of VOCs, however it is the responsibility of the user to ensure the carbon is suitable for their application. For specific applications, please contact us for details.

**Important notice:** Many factors beyond the control of BOFA can affect the use and performance of BOFA products in a particular application, including the conditions under which the product is used. Since these factors are uniquely within the user's knowledge and control, it is essential the user evaluate the products to determine whether the product is fit for the particular purpose and suitable for the user's application. All products, product specifications, availability and data are subject to change without notice, and may vary by region or country.

Think before you print! Please consider the environment before printing this document.

## Combined HEPA / gas filter specifications

Treated activated carbon	23lbs
Other adsorbents	11lbs
HEPA filter media	Borosilicate
Particulate media construction	50mm (0.16ft) maxi pleat construction with glue bead spacers
Gas filter	Treated activated carbon
Filter housing	Zintec mild steel
Media surface area	37.66ft <sup>2</sup>
Filter efficiency	99.995% @ 0.3 microns

## Part numbers

Model	3D PrintPRO 4 - Powder-coated
Part number	1U12760376002-2127-US
PrintPRO silencer stand with air return spigot (75mm)	1UA1060052
Single 75mm Hose Kit 2 meters long to (2,3,4)" port.**	1USHK-O-(2,3,4)
<b>Replacement filter</b>	
Combined HEPA/gas filter	1UA1030469



Approvals: REACH and RoHS. See individual product technical data for specific accreditations

